



WWW.DOUBLEALPHA.BIZ

PRIMEVIBE

USER MANUAL

US PATENT PENDING



Congratulations on your purchase of the PrimeVibe and thank you for choosing our product! This reliable and efficient device will greatly improve your reloading experience, by offering you a simple and fast solution to filling your primer tubes. Both Large and Small Primers!

The PrimeVibe has been carefully designed and manufactured to provide years of reliable service. Please familiarize yourself with the instructions in this manual and, before using the product **watch the video tutorials** available on the Product's page at www.doublealpha.biz.



Warning!

- Handling live primers is inherently dangerous and you do so entirely at your own risk!
- Always wear appropriate eye and ear protection when handling primers and/or reloading.
- Make sure you are familiar and knowledgeable about your reloading process and your ammo specifications.
- Never operate any reloading equipment when under the influence of drugs or alcohol.
- Liability is limited only to replacement of this product or parts thereof. No additional warranties are expressed or implied by the manufacturer or the distributors and resellers.

Contents

In the Box	3
Parts Diagram.....	4
Setup Instructions.....	5
Controller Unit Functions.....	7
Troubleshooting.....	8

In the Box

- Fully Assembled PrimeVibe Unit
- 12v Power Supply, Dual-voltage, with two sets of prongs (US 110v and EU 220v)
- PrimeVibe Controller Unit
- One Large and one Small DAA Primer Tubes, assembled with Magnetic Collars
- Output hole Small/Large conversion kit parts
- Allen Keys, 2.0mm and 2.5mm
- Instruction Manual

Parts Diagram

1. Safety cover
2. Bowl
3. Exit hole cover
4. Steel Disc
5. Exit hole (Large/Small)
6. Output springs (Large/Small)
7. Lowe spring adaptor
8. Electro magnet
9. Leaf Springs
10. Base
11. Controller connector plug
12. Steel Ring
13. Aluminum stand
14. Stand Base
15. Base rubber pads

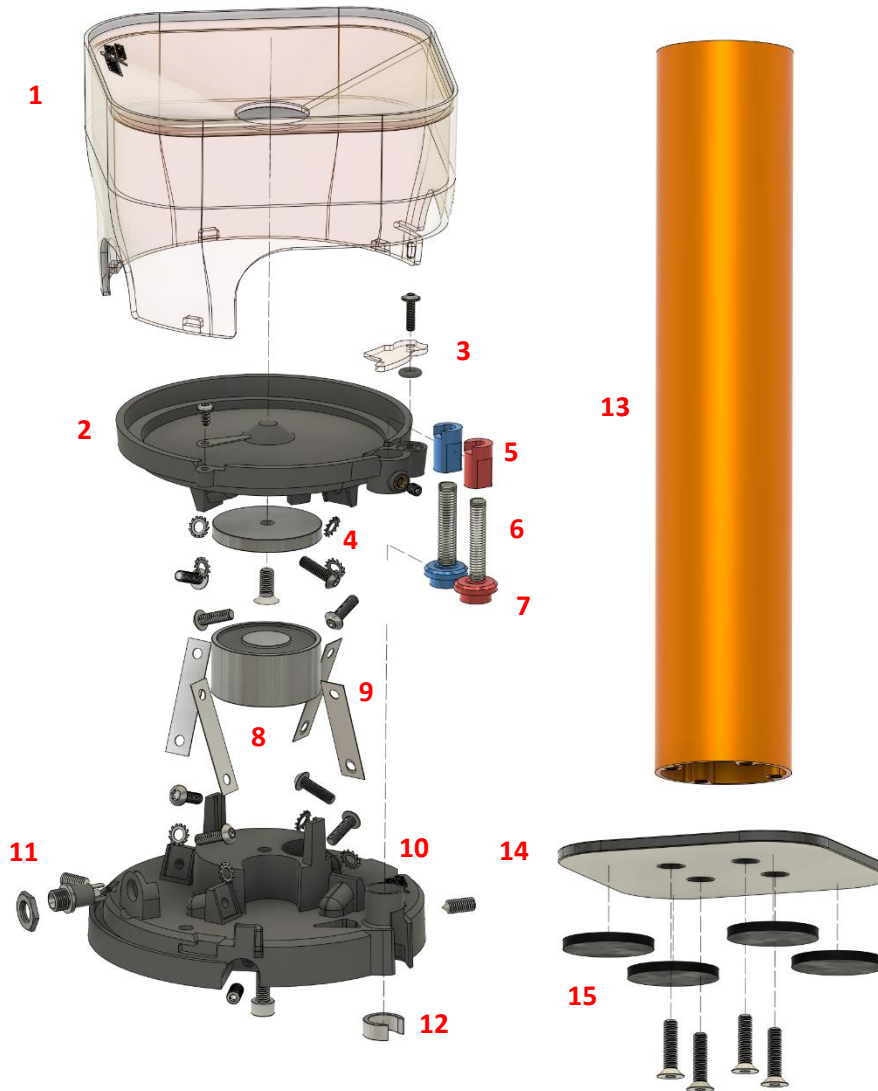

Setup Instructions

1. Remove the Safety Cover by rotating it counter-clockwise while holding the stand. It's held in place with a "bayonet" type connection for easy removal. Rotate until it clicks, then lift up.
2. Rotate the exit hole cover clockwise to open it.
3. Use the included 2mm Allen key to loosen the tightened M4 set screw located on the side of the exit hole.
4. Choose Exit hole assembly parts for either Small (Red) or Large (Blue) primers.
5. Press the Exit hole aluminum piece down into its pocket in the bowl with the Open cutout facing the primer's approach ramp. Ensure it is fully seated with its upper flat surface level with the ramp surface. Tighten the side M4 set screw
6. Insert the selected Lower Spring Adapter into its pocket in the base.
7. Place the selected output spring into the lower adapter, ensuring it's fully seated. Position the top of the spring so it enters the pocket at the base of the aluminum exit hole. Make sure the spring is well-seated by rotating it a few turns.
8. Attach the primer tube. This is held in place magnetically. The height of the magnetic collar on the primer tube has been preset for you, and is very important. The top of the primer tube should make light contact with the bottom of the Lower Spring Adaptor. Contacting it, but not lifting it up out of its pocket in the Base..
9. Unpack the controller and assemble the Outlet Prongs according to your needs. Plug the Controller unit into the power supply and connect the controller to the Controller plug on the side of the base.
10. Rotate the Exit hole cover back to its closed position and reinstall the Safety Cover. Your DAA PrimeVibe is now ready to feed primers.

11. Empty a box of 100 primer into the concave Safety Shield, assisting them to fall through the center hole with your finger.
12. Press the Red button on the controller (Twice, if it was in sleep mode) and the bowl will start vibrating and moving the primers. Follow the instructions on the following page for tuning the bowl using the Controller.

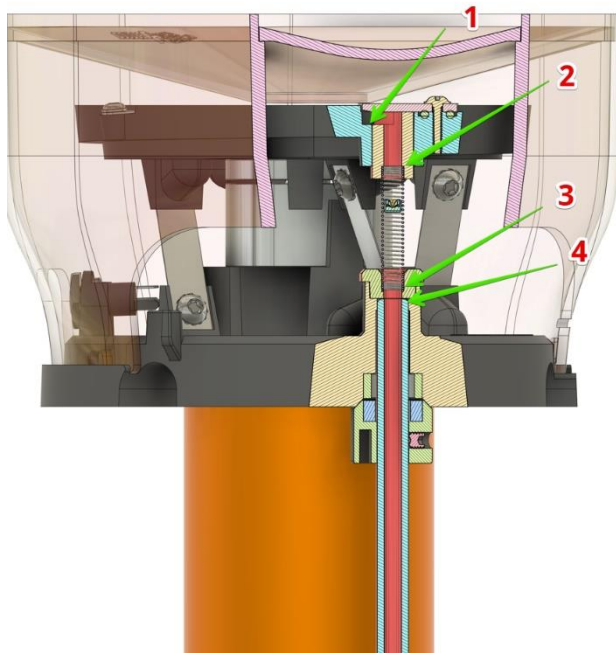

Correctly assembled Primer Output:

1. Exit hole fully seated into its pocket, so the top surface of the exit hole is level with the ramp.
2. Top of Exit Spring fully inserted into the base of the exit hole.
3. Bottom of Exit Spring fully seated into the Lower Spring adaptor.
4. Height of magnetic collar on the primer tube is set correctly, so that the top of the primer tube makes contact with the base of the Lower spring Adaptor, but does not lift it up.

Controller Unit Functions

The PrimerVibe's controller unit allows precise adjustment of the bowl's vibration, crucial for optimal performance with different primer brands.

- Frequency adjustment range: 60.0Hz – 99.9Hz.
- Toggle between fine and rough tune by pushing the left adjustment knob IN.
- In rough tune mode, frequency changes by full numbers per rotation click. In fine tune mode, each click adjusts frequency by one-tenth of a hertz.

Experiment to find the best frequency for smooth primer feeding. Avoid overly quick movements, which can cause primer bouncing and reduce reliability

It's recommended to start around 93.0 Hz and experiment within the 90-95 Hz range, as this is typically optimal for most users.

For best results, adjust the frequency with only a few (10-20) primers in the bowl. The last primers are most sensitive to frequency adjustments, so fine-tuning with a smaller quantity ensures best results.

When the bowl is full, primers push each other up the ramp, making them less sensitive to precise frequency settings.



The Right knob on the controller sets the unit's shutdown delay from 30 seconds to 4 minutes. Most Small Primer tubes fill within 1.5-2.5 minutes, while Large Primer tubes may take a bit longer. Toggle between fine and rough run-time adjustments by pushing the knob in.

Since the PrimerVibe runs very silently, setting the timer to 4min may suite most.

Additionally, the timer offers a 'continuous mode' that keeps the bowl running for 3 hours before shutting down. To activate or deactivate this mode, press and hold the Timer knob for 4 seconds. This feature is useful for those experimenting with attaching the PrimeVibe directly to their press for continuous primer feeding.

Troubleshooting

Primers not Moving well

Spend more time experimenting with the frequency setting. It is normal that the last 20 primers take longer than the first 80. Also check to ensure the unit is standing on a level and solid table.

Last couple of primers fail to output:

This is common to vibratory bowls. They work best with multiple parts pushing each other. When empty, it is possible that a lone primer rotates on its side and gets stuck in that position.

Primers not entering under the exit cover

- The Exit cover is height adjustable. Loosen the screw to allow the cover to lift up slightly.

- Ensure the exit hole piece is fully seated and locked in place. If it lifts up, primers may struggle to reach the exit hole

Primers getting stuck while falling down the exit: this could have several reasons. Check these points:

- The output spring is not seated well into the pockets. Any gape will create a point where primers can hang up.
- The output spring itself is bent or damaged and needs replacement.
- Possibly the top of the primer tube is not making contact with the lower spring adaptor. A gap will prevent smooth primer movement.
- Top of the primer tube has a burr or bad chamfer.
- Buildup of dirt or primer residue in the exit hole parts, clean and dry before reuse.

Correctly orientated primers are falling off the ramp

Most likely you are forcing the primers to move too quickly – causing them to bounce. Slow down the primer movement so that they slide smoothly, by slightly increasing the frequency setting.

An occasional inverted primer is outputting

Adjust the frequency to slow down the primer motion. If the primers are made to feed too quickly, they may push up against one another with enough force to “carry” an inverted primer past the rejection windows. Try to slightly increase the frequency setting.



DOUBLE-ALPHA ACADEMY B.V.

ELZENWEG 33B, 5144 MB WAALWIJK

NETHERLANDS

T: +31 416 660 464

E: DAA@DOUBLEALPHA.BIZ

WWW.DOUBLEALPHA.BIZ

